



REPRESENTATION OF KNOWLEDGE RESOURCE IN THE CONTEXT OF ECONOMIC INTELLIGENCE SYSTEMS

Oladejo Bolanle, David Amos

LORIA, Campus Scientifique, Vandoeuvre les Nancy Cedex Nancy, France
oladejof@loria.fr, amos.david@loria.fr

Osofisan Adenike

Department of Computer Science, University of Ibadan, Ibadan, Nigeria
nikeosofisan@gmail.com

ABSTRACT

Knowledge representation is an essential criterion to capitalization of knowledge in organizations. There is need for organizations to employ strategic methods to ensure optimal innovation and effective decision making. Thus, Economic Intelligence proffers strategy to facilitate effective decision making through collection, treatment and use of relevant information for economic actors in decision making process. There are knowledge and information on actors and from required activities respectively that need be capitalized in order to aid resolution of related future decision problems. It is imperative to establish a system of organization, representation, storage and transmission of these knowledge resources. The goal of this study is to provide adaptable framework and user-centered knowledge model for the representation and exploitation of knowledge in the decision making projects of the Economic Intelligence process by acquiring, organizing, integrating and capitalizing such knowledge in order to exploit it for reuse and sharing.

KEYWORDS

Knowledge, Knowledge resource, Knowledge representation, Knowledge Capitalization, Economic Intelligence (EI), knowledge exploitation.



INTRODUCTION

The success of any socioeconomic organization concerns the management of its 'knows' and 'know-hows'. These include knowledge, experiences and skills of the organization. Socioeconomic organization structure may include any individual or collective ability to innovate and make strategic decisions. Economic Intelligence (EI) serves as a key for achieving strategic decisions. EI provides the resources that are enacted upon by actors to address decision problems in order to generate relevant information that resolves such problems ((Kislin et al., 2002). The resources, actors, as well as information solution to decision problems constitute essential knowledge in the context of EI. Such knowledge could foster resolution of future problems that are related to the past ones. This benefit could only be feasible if the knowledge is acquired and stored. Thus, its representation with an appropriate formalism is required. It is only then knowledge can serve as a key for innovation in an organization with respect to its decisionmaking needs. The goal of this paper is to develop appropriate methods for capitalizing knowledge of decision-making projects of EI. We propose the use of an adaptable framework for representation and capitalization of such knowledge. The challenges of the research revolve around the required methods for acquisition, harmonization, and representation of knowledge of EI actors and activities. We generate a relational model based on the proposed framework to capture and represent knowledge. The main purpose of this model is to enable possible exploitation of stored knowledge in order to obtain relevant solution to new needs with less efforts and time. The paper is divided into five sections. The first section introduces the motivation for and goal of the research. The related theoretical concepts are discussed in the second section. Our approach of representing knowledge in the context of EI constitutes the third section. The result observed from the implementation of the proposed framework for knowledge representation and capitalization is discussed in the fourth section. The paper is concluded by a summary of contribution and direction for future work.

THEORETICAL BACKGROUND

The concept of knowledge with the success criteria for its representation and exploitation is brought to limelight here. The viewpoint of Economic Intelligence with respect to information and the significance of knowledge required to achieving its goals are addressed in this section.

Knowledge

There are several notions about knowledge from literatures. From philosophical point of view, it is referred to as justified true belief. This indicates that it is a belief. However, belief is a mental attitude or state of mind: a personal conviction or acceptance of a particular fact or idea. Most contemporary philosophers characterize belief as a 'propositional belief'. It cannot be regarded as knowledge due to the fact



that it is only a disposition (Stanford Encyclopedia of Philosophy, 2006). Also, (Blackburn 1999) disputes that whatever the form of belief it cannot be regarded as knowledge. Thus, from epistemology (the study of knowledge), it is referred to as a perception or observation of an object or event as well as skill for or experience in performing an activity. There is another view of knowledge with respect to socio-economic perception.

Knowledge is referred to as a capital which has an economic value, and also serves as a new strategic resource for increasing productivity. (Matta et al in Dieng-Kuntz and Matta, 2002). This view is reinforced by Stata's (1989) opinion that knowledge is the primary source of wealth in industries and traditional sectors of economy. This description of knowledge fails to pinpoint what it actually depicts or means. According to Pohl, (2002) knowledge is defined as the addition of context to information where the latter is defined as the existing relationships among data i.e. numbers and words. In (Miller, 2002) knowledge is defined in terms of interpretation attributed to given information as claimed by the author that "information is intrinsically meaningless on its own and remains so unless – and until – it is interpreted by human beings, within some context". We take side with this view of knowledge. From a critical and logical point of view, information could be seen as a message which has its borderline from which knowledge takes its landmark. That is to say, they are related and inseparable but distinct. Knowledge adds value to information when it (the latter) is analyzed with respect to surrounding circumstance or related facts. We conclude with the notion that knowledge refers to facts with its attributed meaning, where meaning is a function of an observation, learning, experience, and understanding of a reality in a particular situation or context at a specific period of time by an individual. Figure 1 summarizes our view. There is need to consider the classification of knowledge for the purpose of its representation.

Figure 1: what is knowledge?

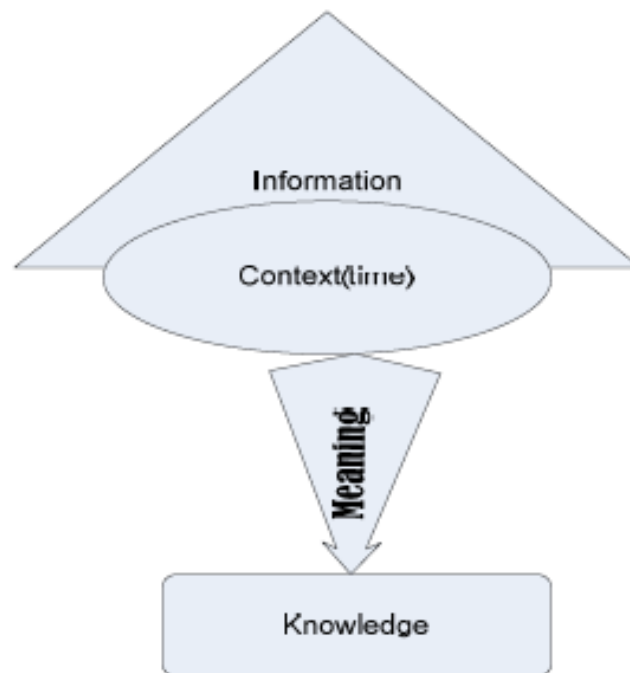

Classification of Knowledge

From philosophical point of view, there are two kinds of knowledge with respect to experience, namely *priori* and *posteriori* knowledge (Stanford Encyclopedia of Philosophy, 2006). *A priori* knowledge is independent of experience, while *a posteriori* knowledge is dependent on experience. However, from (Prusak, 2000): four kinds of knowledge are identified namely *episteme*, *techne*, *phronesis* and *metis*. *Episteme* refers to scientific principles while *techne* indicates technical know-how and community of practice.

Phronesis refers to practical wisdom from social practice and *metis* is a form of practical knowledge. Nonetheless, there are two major types of knowledge: explicit (objective) and tacit (subjective) Knowledge. (Nonaka & Takeuchi, 1995). Table 1 gives a summary of this classification.



Table 1: Types of knowledge

Explicit (episteme)	Tacit (techne)
Formal and systematic	Insights, intuitions, and hunches (<i>Phronesis</i>)
Knowledge of rationality (mind)	Knowledge of experience (body) (<i>Metis</i>)
Can be expressed in words and numbers	Not easily visible and expressible: it resides in people's heads
Easily communicated and shared in form of data, formula, graphs, manuals, books, documents, or theories etc.	Highly personal, hard to formalize, difficult to communicate or share with others
Can be expressed in computer code, databases, simulations, sets of general principles etc.	Rooted in individual's actions and experiences: in form of rules of thumb, ideals, values, or emotions.

Explicit knowledge could be expressed in form of theoretical and practical experience. It could be readily transmitted across individuals formally and systematically. On the other hand, tacit knowledge is in form of skill and it is highly personal and hard to formalize, thus, difficult to share with others. An obvious challenge is the issue of transformation of tacit knowledge into explicit knowledge in order to represent it in a way to aid its exploitation.

Transformation of Knowledge

There is need to explore tacit knowledge resource of an organization in order to represent and share (capitalize) it for optimal economic value. As earlier mentioned, explicit knowledge is already in a form which is easy to capture and formalize, on the other hand, it is not so for tacit knowledge. Thus, it requires a transformation process to convert it to explicit knowledge before it could be capitalized or managed. There are four modes of conversion involved in this process namely, socialization, externalization, internalization and combination (Nonaka and Takeuchi,1995). Table 2 describes the transition between tacit and explicit knowledge for each of the modes. Organization can only become innovative and can gain a competitive advantage when it recognizes the significance of knowledge of both individual and group involved in its operation and who contribute to its existence. This realization on its own does not suffice unless there is a conscious effort directed towards acquisition and representation of existing knowledge. Then will it become feasible to exploit the knowledge in addressing new problem. Thus, this necessity requires the method of capitalization of knowledge.



Knowledge Capitalization

Knowledge Capitalization (KC) can be viewed as the task of mapping the existing knowledge of an organization in terms of the stored information which entails the specific states, (*what, when and how*) of decision taken to a current similar decision-problem in order to re-use the knowledge (Dieng-Kuntz and Matta, 2002). In other words, to capitalize knowledge means “to reuse, in a relevant way, the knowledge of a given domain previously stored and modeled, in order to perform new tasks” (Simon, 1996). This knowledge is stored in a database called “corporate memory” or organizational memory.

Corporate memory refers to a structured set of knowledge related to the firm experience in a given domain. It is also a “repository of knowledge and know-how of a set of individuals working in particular firm” (Euzenat, 1996). In a Knowledge Capitalization task, it is essential to identify the crucial expert/domain knowledge in order to determine the required kind of corporate memory (CM) that would “support the integration of resources and know-how in the enterprise and the co-operation by effective communication and active documentation” (Durstewiz, 1994). Subsequently, the knowledge could be formalized and modeled in a corporate memory for re-use and update by designated users. In this work we aim at representation, integration, sharing and reuse of knowledge in Economic Intelligence projects.

Economic Intelligence

Economic Intelligence (EI) is a set of coordinated actions of search, processing and distribution for exploitation of useful information for economic actors. These actions are carried out legally with all the necessary protection for the safeguard of the company’s patrimony, and with the best quality, delay and cost (Martre, 1994). Information is needed at various levels of decisionmaking process of a company or community to develop a coherent strategy and tactics necessary to achieve the goals set by the company in order to improve its position in its competitive environment. These actions are to be structured in a continuing cycle in order to track and capitalize the knowledge resource.

The process of EI, according to SITE research team (SITE Report, 2007) entails the phases highlighted below.

- a) Identification and definition of a decisional problem
- b) Translation of the decisional problem to an information search problem
- c) Identification of relevant information sources
- d) Collection of relevant information
- e) Analysis of the information collected to extract indicators for decision
- f) Interpretation of indicators
- g) Decision-making



The EI research develops methods for identifying relevant sources of information, analyzing the collected information and manipulating it to provide what the user needs for decision making.

There are four major economic actors involved in the decision-making process who are responsible for playing key roles in performing the required tasks for ensuring the success of the process. Each actor has a designated responsibility as discussed below.

- **Decision maker** who must formulate exact description of the decision-problem.
- **Watcher** who must locate, supervise, validate and emphasize the strategic information needed for solving the problem.
- **Information system analyst/designer** who supports the watcher in information retrieval task.
- **Project Coordinator** who serves as a link between decision-maker and watcher as well as end-users (Knauf, 2007).

All the actors work together in collaboration in order to optimize sharing of strategic knowledge amongst one another. Thus, EI is decision-maker-centered as information needs are treated based on the contexts of the decision-maker. There are existing models in EI for representing knowledge. They serve as tools for the various phases of EI process in decision-making activities. They are designed to represent knowledge in the different stages of EI process. They are as follows.

- **MEDP**(Model for Explicit definition of Decision Problem): This model handles the first step of EI process by clarifying the decision problem. It combines both the context of the problem, the decision-maker and the challenges of the decision-making problem to identify the real needs of the decision maker for information and preparation of the information research project by addressing two major questions: *what the need is and its purpose* (Bouaka, 2004).
- **WISP**(Watcher's Information Search Problem): It relates to the second phase of EI process. It represents a methodology for translating the decision problem into information retrieval problems (Kislin, 2007).
- **MIRABEL**(Model for Information Retrieval query Annotations Based on Expression Levels): It expresses the equivalence between a given decision problem and the corresponding specification of information retrieval problem (Goria, 2006).
- **MORPRI2E**(Model for the representation of Information Search Problem in Economic Intelligence): It is meant to represent users with respect to their specific needs and its context and to model an information system which adapts to the changing needs of users (Afolabi, 2007).
- **RUBICUBE**(Representation of User's needs at the time of Identification and Interrogation of an Information System): It adapts information system design to users' types of needs in the design of a multidimensional data warehouse of document resources (Peguiron, 2006).



- This and MORPRI2E consider the third and fourth phases of EI process AMIE(Annotation Model for Information Exchange): This relates to the fifth and sixth phases of EI process. It expresses information relevance and reliability by analyzing and annotating collected information and its contexts (Robert, 2007).
- CADRIE(Specification of the competence of the moderator of Regional Economic Intelligence): This Model specifies the roles and the competences of the coordinator of a regional economic intelligence for managing EI actors and their activities (Knauf, 2007).

These different models are used to represent the tacit knowledge or skill of actors with respect to the specific phases of EI process. There is a need to integrate all these models in order to realize the following benefits:

- Preservation or storage of valuable knowledge resources in activities of EI projects.
- Provision of platform for integration of models, information research skills, results etc.
- Possibility of solving new problems with existing relevant knowledge resources.

Success criteria for representation and exploitation of knowledge

We consider the essential factors for knowledge representation and capitalization in order to explore maximal benefit of its exploitation.

Principles of Knowledge Representation

According to (Randall et al., 1993 in Sowa, 2000), five factors contribute to adequate representation of knowledge. The following considers each of these principles.

- Knowledge representation should serve as a surrogate (substitute/stand-in) for physical objects or events and the relationships amongst them with the aid of symbols and its links to model an external system.
- It is a set of ontological commitments that determine various categories of objects of a domain.
- It should describe the behavior and interaction amongst domain objects in order to reason about them.
- Next is the fact that knowledge representation should be a medium for efficient computation which enables the encoding of represented knowledge in order to facilitate efficient processing with the aid of appropriate computing equipment.
- Finally, it should be a medium of human expression in such a way to facilitate the understanding and communication of both knowledge engineer and domain experts.

We apply these principles to the development of a knowledge repository (corporate memory) for EI in section 3.



Reasoning Techniques in Knowledge Representation

Knowledge representation is often augmented with reasoning (the process of applying knowledge to arrive at conclusion) techniques: that is, provision of methods to handle the tracking of transition among system's properties or knowledge and underlying reasons for such transitions. There are two approaches to reasoning techniques, namely, declarative and procedural. The latter is similar to step-wise programming or algorithmic approach while the former requires the use of axioms or logical statements to describe specifications and theoremproving technique to reason about knowledge (Sowa, 2000). The choice of appropriate techniques for representing and reasoning about domain knowledge actually depends on the nature of requirements for knowledge-based system.

Sowa recommends the use of a procedural approach for representing a system which requires a natural sequence of operations of its processes. On the other hand, logic is best suited for modeling a system in which there is no time sequence or linear pattern of relationships amongst its processes. We choose the procedural approach due to the fact that our context of EI represents a process which entails a sequence of stages or phases (as stated in section 2.3).

Representation and Exploitation of Knowledge in Economic Intelligence

The goal of this paper is to capitalize knowledge in EI-based projects by acquiring, organizing, integrating, representing and storing such knowledge in order to exploit it for re-use and distribution. The challenges confronting us relate to the acquisition, harmonization, and representation of knowledge resources from EI activities. Also, there is need for an appropriate reasoning technique to facilitate exploitation of relevant information.

Our approach is to identify, design, and represent knowledge resources and to integrate EI models/tools for performing EI tasks. We have identified the knowledge resources in section 2.3.

After identification of the knowledge resources of EI projects, the structure and representation of knowledge resources is an important factor just as a foundation is to a building. Thus, we design an adaptable user-oriented framework to serve as the bedrock for the representation of the proposed work.

Framework for Knowledge capitalization of EI projects

Our approach is to design an adaptable framework for capitalization of EI projects such that

diverse problem domains requiring resolution of decision problems can be adequately catered for. The framework serves as a base to the modeling and development EI knowledge repository. Figure 2 illustrates the general framework of Knowledge Capitalization in EI.

Figure 2: General framework of Knowledge Capitalization in EI

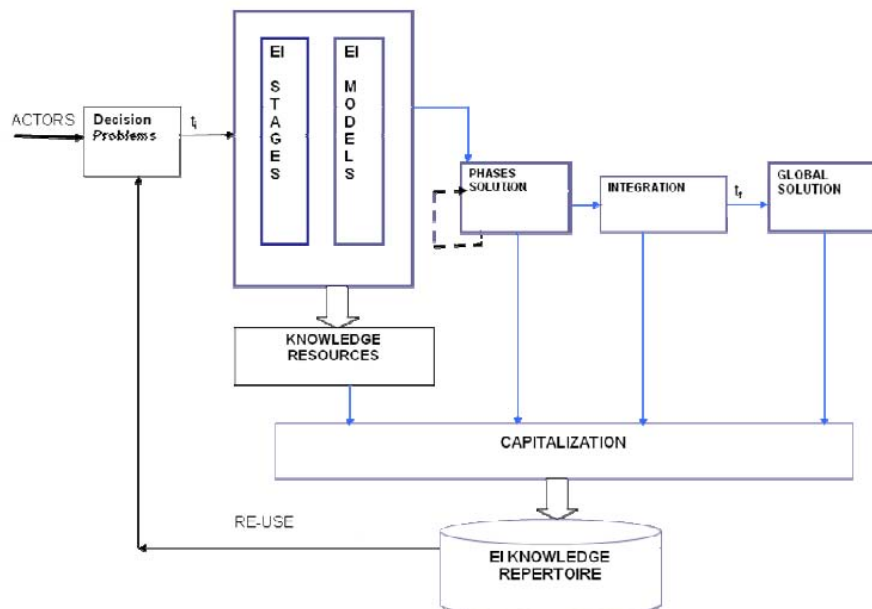

This framework organizes the knowledge resources of EI capitalization system. The actors and the roles they play or their tasks serve as the drivers or determinants of the transition from one phase to the other in a given project of decision problem. The EI process is decomposed into the various phases that depict the tasks to be carried out. On the other hand, the EI models that serve as the tool or methods of problem resolution are applied to respective task of actor(s). The framework harmonizes all the knowledge resources of each EI model into a single pool. Knowledge resources on actors, tasks, tools, time-stamps and information results are integrated and stored into the knowledge repository. These knowledge resources could be exploited for reuse when actors explore available resources to address new problem case. The framework leads to the modeling of relational schema of EI knowledge repository.



Experimentation of the Framework and Model with a Prototype

We build “EI Knowledge repertoire” for knowledge resources and its time-stamps in EI activities. We apply the user-based search technique for exploration of the Repository for identical cases of knowledge resources.

Experimentation

The described framework and relational model in section 3 are implemented with a prototype to simulate the acquisition and representation of knowledge resources of a scenario of decision problem. The prototype also demonstrates the exploitation of knowledge for possible reuse. We consider a sample decision problem. It is ‘moral decadence amongst youth’. Figure 4 depicts the knowledge resources of the first phase of EI process. The knowledge resources are identified with respect to the EI tools or models applied by actors and tracked for storage. The following section indicates the knowledge resources of resolving the decision problem.

Case Study of Decision Problem of Moral Decadence amongst youth

The framework provides a template for the capitalization of knowledge resources in the given case study. That is, knowledge resources are identified and acquired from the actors and activities involving the phases of EI process and respective models. The following scenario exemplifies the knowledge resources in the first phase of EI process.

Scenario

Decision maker states the decision problem (DP) as: *Moral decadence amongst youth*

The Context of Decision Problem is Educational sector in Nigeria.

Understanding the Decision problem: What is the meaning of the decision problem?
(This helps to acquire the knowledge of DP.)

The terms or concepts of the DP are defined by the Decision maker as thus:

- Moral refers to principles or rules of right conduct.
- Decadence is a state of decline in moral.
- Moral decadence implies a state of decline or deterioration in conformity to principles or rules of right conduct.

Thus, moral decadence amongst youth implies a state in which teenagers or secondary school aged people decline in conformity to rules of right conduct.

Definition of the Stake of DP:

- Object: *Moral decadence*
- Signal: truancy, violence, crime, immorality.
- Hypothesis: If DP is not curbed then there would be:

Figure 4: Scenario of a decision problem

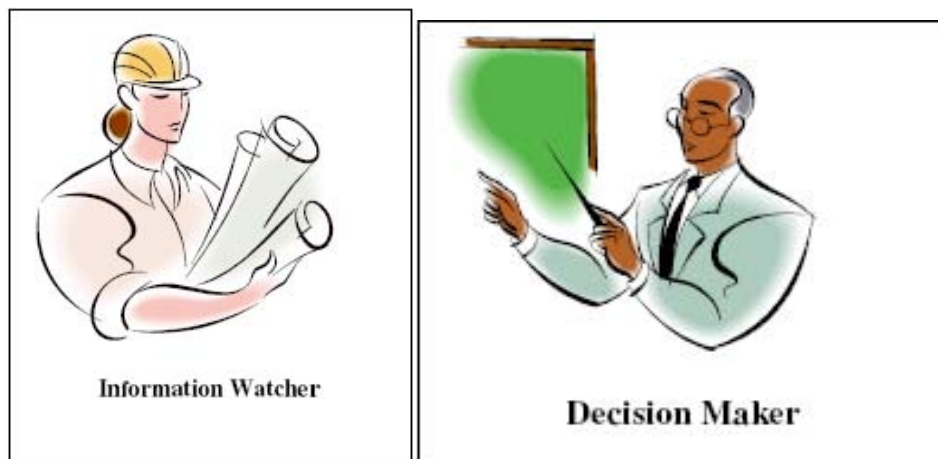

Decision Maker
DECISION PROBLEM (DP)
Moral Decadence among the youth

Educational System in Nigeria

Identifying WHAT knowledge to be capitalized on:

- Decision Problem
- Economic Actors

Decision Problem

Interpretation of the DP based on:

- Identifying and defining the keywords in the DP
- Relating the keywords within the given context

Economic Actors

Information on the actors based on their profiles such as:

- Area of Specialization

- Years of Experience
- Educational Background, etc

Information Watcher

- High percentage of school drop outs.
- A bad omen for the state of future leadership.
- Social menace.

The terms or concepts of the DP are interpreted by the watcher as well. Both actors assess the individual viewpoints and resort to a specific definition of the decision problem.

Acquisition and Representation of EI Knowledge and resource

We simulate the acquisition and representation of knowledge resources of the above scenario based on the proposed relational model. Figure 5 depicts the access page to actor-action based information entry. The identification and definition phase of the EI process is illustrated in figures 6.

Figure 5: Access Verification for Actor-action Forms

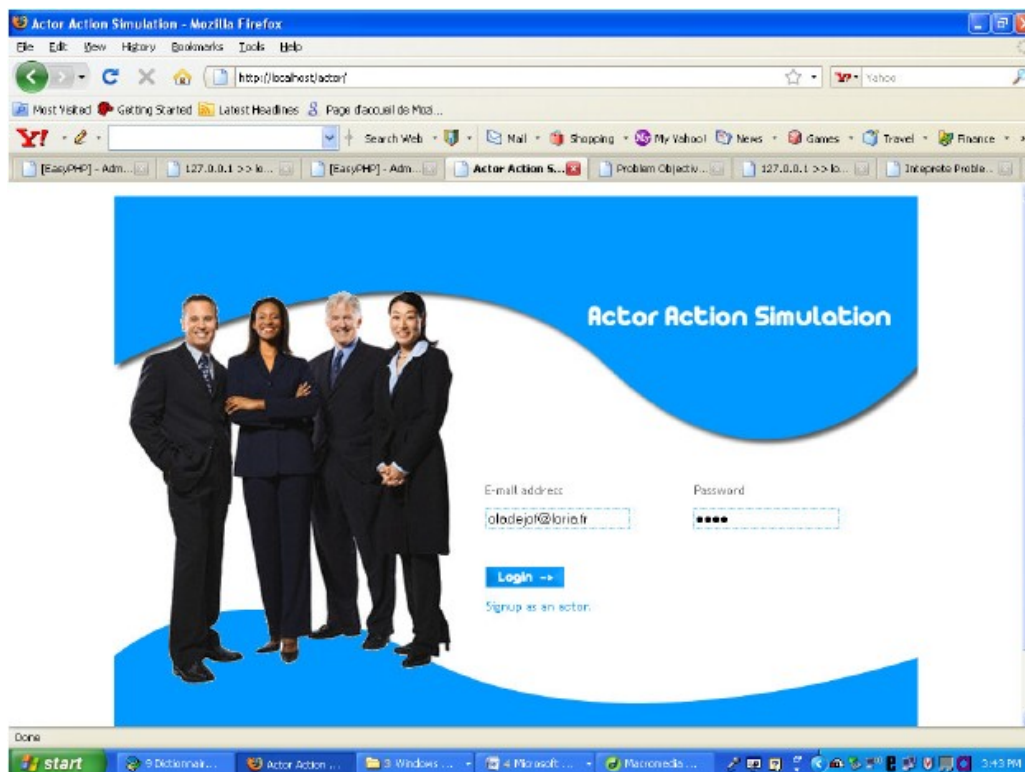
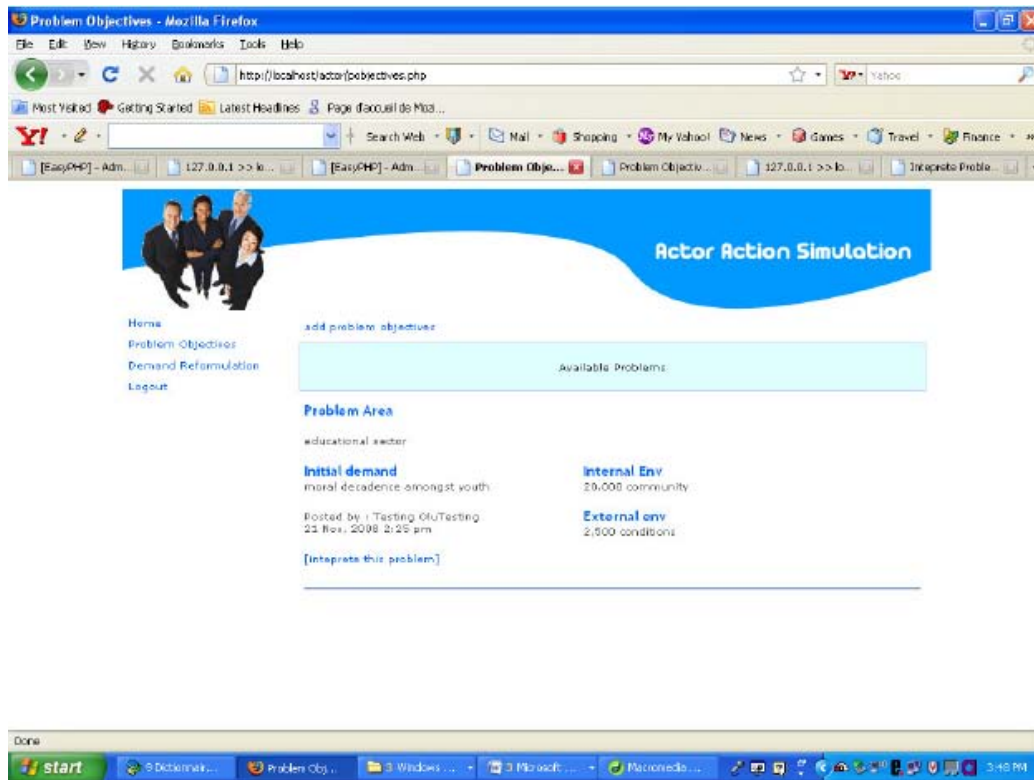

Figure 6: Identification and Definition of Decision Problem



Exploitation of Knowledge

The purpose of representing knowledge resources in EI projects is to allow the users or actors to exploit it for reuse. We propose to use a search technique called EQuA2te meaning 'Explore, Query, Analyze, Annotate' (David & Thiery, 2003). It allows user's query to be formulated in a way that best describes the contexts of user's needs. Figure 7 illustrates one of the methods of the chosen technique in which attributes of knowledge resources that are related to an actor's role could be selected to retrieve specific instances of knowledge resources.

Figure 7: Exploitation of Knowledge Resources

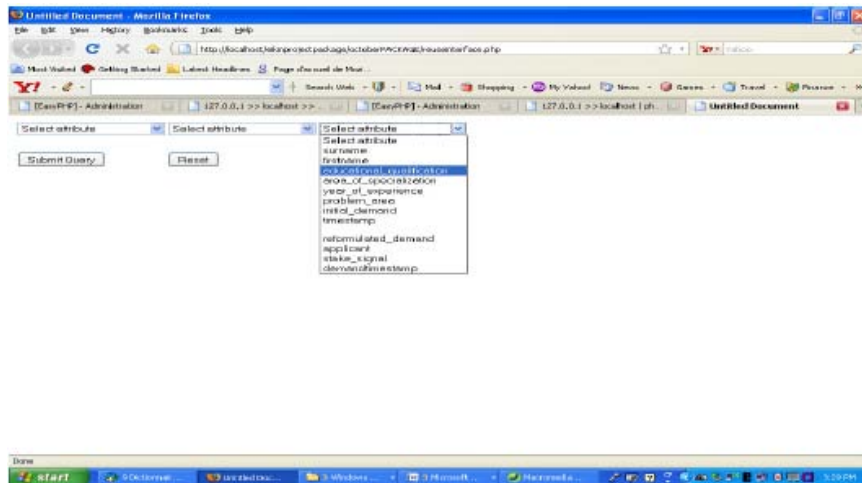

CONCLUSION

Knowledge is a key for innovation and for gaining competitive advantage. We have taken cognizance of this fact by providing adequate methods to represent and to capitalize knowledge. In this paper, Economic Intelligence has been presented as a strategic tool or method which aims at providing relevant information for resolution of decision problems. This target of EI can be ameliorated or optimized by the possibility of capitalizing knowledge in order to reuse it to solve related future decision problems.

We designed an adaptable framework which serves as a platform for modeling and organizing knowledge resources in the context of EI. The relational knowledge model facilitates the acquisition, representation and harmonization of knowledge in EI projects. We implement a prototype to demonstrate the development of a knowledge repository and its exploration. This consequently aids actors to exploit stored knowledge for reuse in new problem cases. The main benefit of this work is the possibility of exploring the knowledge resources based on the role of actor(s).

We propose to extend the framework and consequently the model with feedback strategy such that it will be possible to validate the relevance of exploited knowledge resources. We propose further to integrate the update of knowledge resources into the prototype system.

REFERENCES



AFOLABI B. (2007). La conception et l'adaptation de la structure d'un système d'intelligence économique par l'observation des comportements de l'utilisateur. Thèse de doctorat, Université Nancy 2, France.

BLACKBURN S. (1999). Truth: A Guide, Oxford University Press.

BOUAKA N. (2004). Développement d'un modèle pour l'explicitation d'un problème décisionnel: un outil d'aide à la décision dans un contexte d'intelligence économique. Thèse de doctorat, Université Nancy 2, France.

DAVID A., THIERY O., (2003). "L'Architecture Equate2 et son Application à L'intelligence Economique", Article No 98, Nov. 2003. <http://www.isdm.org>

DIENG-KUNTZ R., MATTA N. (2002). Knowledge Management and Organizational Memories, Kluwer Academic Publisher, Boston.

DURSTEWIZ M. (1994). Report on workshop on Corporate Memory, Toulouse, <http://www.delab.sintef.no/MNEMOS/external-info/cm-eurisko.txt>

EUZENAT J. (1996). Corporate memory through cooperative creation of knowledge bases and hyper-documents. Proc of KAW'96, Banff, Canada.

GORIA S. (2006). Proposition d'une démarche d'aide à l'expression des problèmes de recherche d'informations dans un contexte d'intelligence territoriale. Thèse de doctorat, Université Nancy 2, France.

KISLIN P. (2007). Modelisation Du Problème Informationnel Du Veilleur. Thèse de doctorat, Université Nancy 2, France.

KISLIN P., DAVID A., THIÉRY O. (2002). A model of information retrieval problem in Economic Intelligence context. SCI'2002, Orlando, Florida, USA, July 14-18, 2002.

KNAUF A. (2007). Caractérisation des rôles du coordinateur – animateur : émergence d'un acteur nécessaire à la mise en pratique d'un dispositif régional d'intelligence économique, thèse de doctorat, Université Nancy 2. Octobre 2007.

MARTRE H. (1994). Intelligence économique et stratégique des entreprises. Travaux du groupe présidé par Henri Martre, Paris : La documentation Française.

MILLER F.J. (2002). $I = 0$ (Information has no intrinsic meaning), Information Research, Vol. 8 No. 1, October 2002.



NONAKA I., TAKEUCHI H. (1995). *The knowledge-Creating Company: How Japanese Companies Create the Dynamics of Innovation*. Oxford University Press.

PEGUIRON F. (2006). *Application de l'Intelligence Economique dans un Système d'Information Stratégique universitaire : les apports de la modélisation des acteurs*. Thèse de doctorat, Université Nancy 2, France.

POHL J. (2000). *Transition from Data to Information*. CADRC Technical Paper, November 27.

PRUSAK L. (2000). "Knowledge—Can It Be Managed?" presented at the IBM Academy of Technology Conference on Knowledge Management, Fishkill, NY, June 27–29, 2000.

ROBERT C. (2007). *L'annotation pour la recherche d'informations dans le contexte d'intelligence économique*, Thèse de doctorat, Université Nancy 2, février 2007.

SIMON G. (1996). *Knowledge Acquisition and modeling for corporate memory: lessons learnt from experience*.
<http://ksi.cpsc.ucalgary.ca/KAW/KAW96/KAW96Proc.html>.

SITE. (2007). "Modeling and Development of Economic Intelligence Systems", Activity Report, 2006. <http://www.inria/recherche/equipes/site.en.html>

SOWA J. F. (2000). *Knowledge Representation: Logical, Philosophical, and Computational Foundations*, Brooks Cole Publishing Co., Pacific Grove, CA.

STATA R. (1989). *Organizational learning - the key to management innovation*, Sloan Management Review, 30, Spring, 63-73. The Stanford Encyclopedia of Philosophy (2006). Edward N. Z. (ed.), URL= < <http://plato.stanford.edu/entries/epistemology/>>.